

Allegan County 4-H



Horsemaster Level One

Name: _____

Address: _____

City: _____ Zipcode: _____

4H Age: _____ Club Name: _____

Leader's Name: _____

Date: _____



MSU is an affirmative-action, equal-opportunity employer. Michigan State University Extension programs and materials are open to all without regard to race, color, national origin, gender, gender identity, religion, age, height, weight, disability, political beliefs, sexual orientation, marital status, family status or veteran status.

ALLEGAN COUNTY 4-H HORSEMASTER PROGRAM

LEVEL ONE

Level one in the Horsemaster Program is the beginning of the 4-Her's contact and association with horses. It is also the beginning of their experiences in the Allegan County Horse & Pony Project program.

To complete Level One, each 4-H Member should be able to:

- Identify 10 parts of the horse
- Identify proper feeds
- Learn how to properly tie a horse
- Identify 10 safety precautions
- Identify proper grooming tools (examples)
- Identify parts of a saddle and bridle
- Identify two horse colors (picture and descriptions)
- Identify one breed of horse (picture and characteristics)

**** You must earn a 85% or higher score to pass HorseMaster Level One****

Horsemaster Level booklets have been combined with the Allegan County 4-H Horse Notebook program.

The requirement for Notebooks are following (in this order):

1. Decorative cover
2. Title page (must have title, name, club, year in project)
3. Table of Contents or Index (updated each year)
4. Current year personal story and pictures (Should include: name, age, school grade, family, pets, description of horse/pony, what was learned in the project year, other projects, club activities, non 4-H activities and goals.)
5. Horse & Pony Feed & Care Record and Stable Record Card (4-H 1072 & 4-H 1073) (12 months required September 1 - August 31)

Yearly requirements:

- a. Reports pertaining to subject (all articles from magazines must have a summary of what you learned from it.)
- b. Diagrams, pictures drawn or cut out
- c. Samples or collections and they must be attached to the notebook.

A notebook should be neat and clean.

1. Pages should be neatly arranged, numbered and put in **protective covering**.
2. All reports can be in longhand, typed or done on computer.
3. Notebooks **must** be indexed by years and have dividers between each year and numbering sequence.
4. Pages should be written so they are easily read.

Notebooks should start with the member's current year in the 4-H Horse Project and then added in as desired. (Example: 4th year member starts with 4th year notebook requirements and may add in earlier year requirements as desired).



A Little Bit About My Horse

Place a picture of your horse here

Name of Horse: _____

Breed: _____

Gender: _____ Age: _____ Color: _____

Where is your horse kept? _____

Who helps you care for your horse? _____

Identify 10 Parts of the Horse (10 points)

*Withers

*Neck

*Shoulder

*Knee

*Hoof

*Tail

*Mane

*Back

*Eye

*Rump

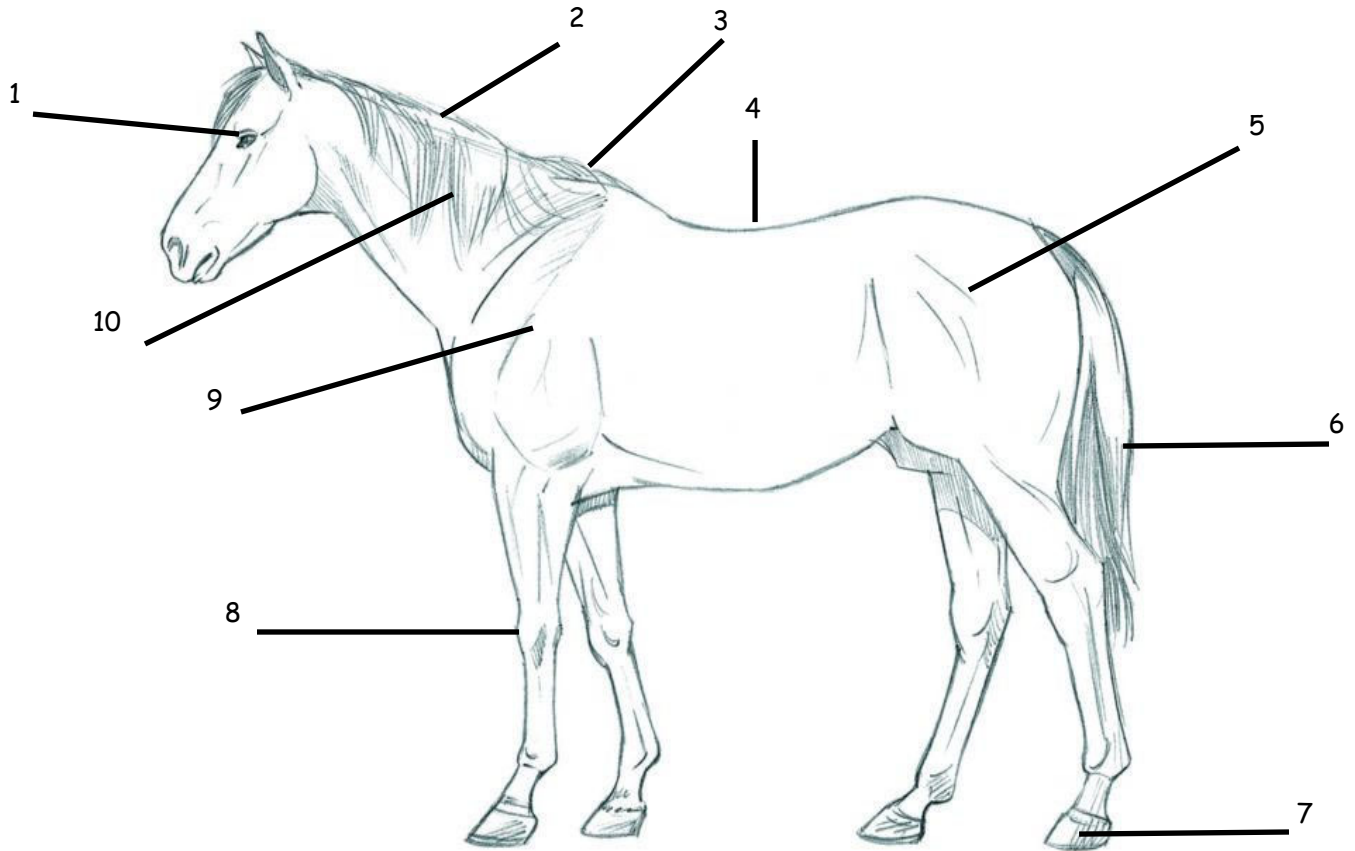

1. _____

2. _____

3. _____

4. _____

5. _____

6. _____

7. _____

8. _____

9. _____

10. _____

Identification of Proper Feeds (5 points)

Feeding and Nutrition

An average horse (1000 lbs. body weight) will consume approximately 15 to 20 pounds of a combination of hay, pasture and grain (total ration) each day. The major component of a horse's diet is good forage such as alfalfa, grass hay or pasture. Horses require five types of nutrients:

1. Water
2. Energy (carbohydrates and fats)
3. Protein
4. Vitamins
5. Minerals

*Provide pictures of some of the essential feeds below.



Place a picture of hay here



Place a picture of grain here



Place a picture of oats here



Place a picture of a salt block here

How Well Do You Know Your Feeds? Take the Quiz! (10 points)

*Sugar

*Oats

*Corn

*Hay

*Water

*Apples

*Alfalfa

*Carrots

*Barley

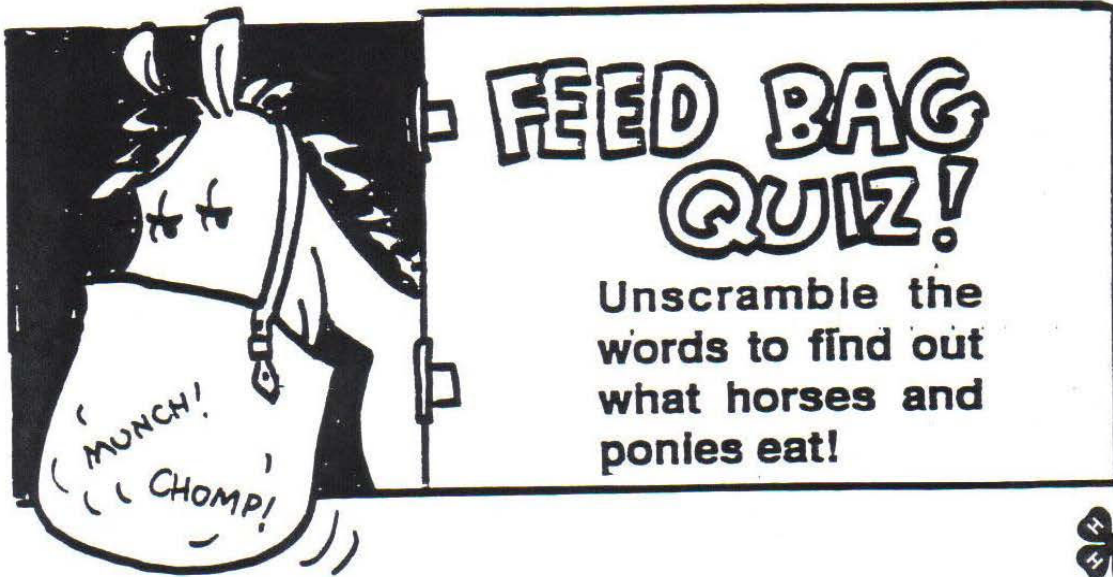

SAGRS _____

PLASEP _____

SATO _____

RONC _____

AWERT _____

LAAFLAF _____

YHA _____

REBYLA _____

TORCSAR _____

How To Properly Tie a Horse (5 points)



To horse
The end of the halter rope goes under then around the pole



The loop is put through the first loop . . .



The rope goes under itself

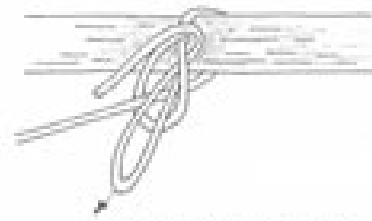

. . . and pulled through and tightened

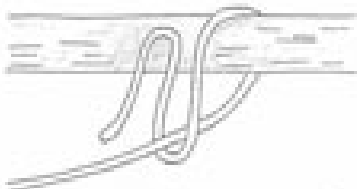

The end of the rope is doubled into a loop



Pull to untie
The finished knot

****Please demonstrate with a parent or your 4H leader that you know how to properly tie a horse.****

Date completed: _____

Signature of parent/leader: _____

Ten Safety Precautions (10 points)



Please fill in the blanks with the correct word listed below. Please reference: <http://www2.ca.uky.edu/agcomm/pubs/4af/4af05ma/4af05ma.pdf>.

*length *behind *red *beside *unsafe
*protective *reins *barefoot *calm *blind spots

1. Always wear _____ headgear.
2. Excessive speed on the trail is _____.
3. When your horse becomes frightened, remain _____, speak quietly, steady it and give it time to overcome its fear.
4. Ride or stay a full horse's _____ from the horse in front to avoid the possibility of being kicked.
5. A _____ ribbon tied into the tail indicates a kicker, so stay back.
6. Never tie your horse by the _____, he may pull back and break the reins or injure his mouth.
7. When leading your horse, walk _____ him, not ahead or behind him.
8. Never stand directly _____ a horse or directly in front of him.
9. When working around your horse, wear boots or hard-toed shoes to protect your feet.
Never wear tennis shoes, moccasins or go _____.
10. Horses have " _____ " in front of their nose and directly behind them.

Horse Safety (10 points)

Color the pictures. Place a circle around the pictures that shows the rider being safe and an X through the picture that shows the rider not being safe.

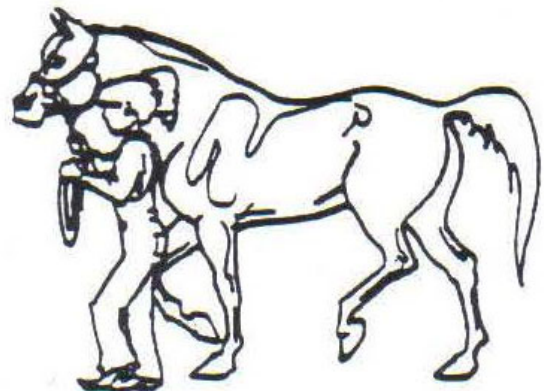
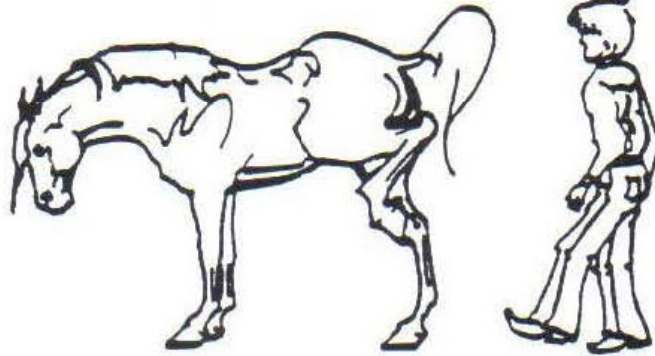
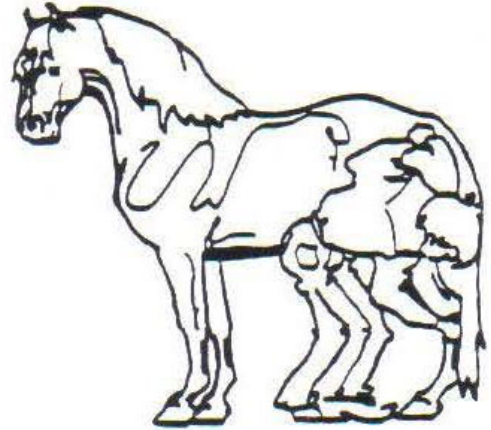
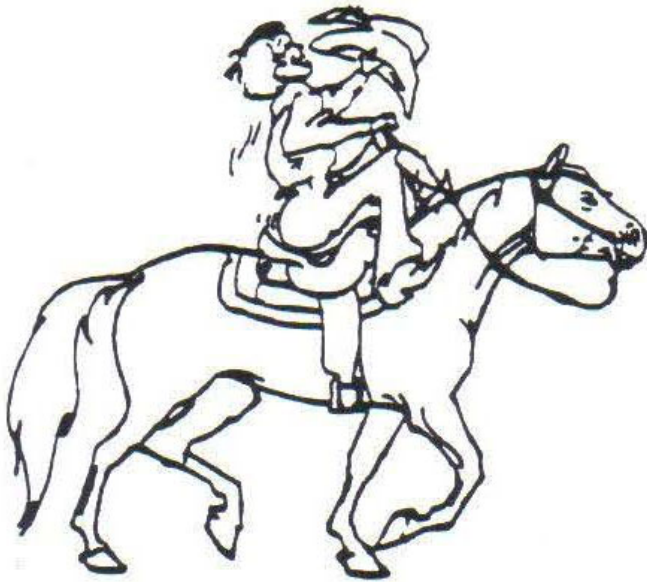

Proper Grooming Tools (10 points)

Write in the letter that correctly matches the grooming tool.

Hoof Pick _____

Dandy Brush _____

Curry Comb _____

Body Brush _____

Mane Comb _____

Sponge _____

Cloth _____

Grooming Box _____

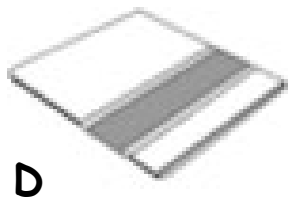
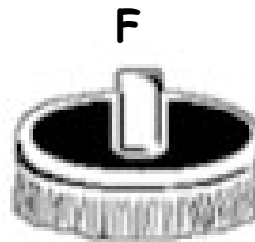
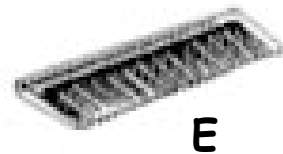
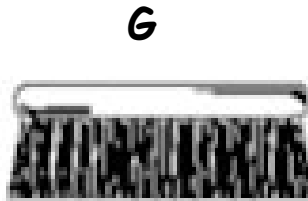
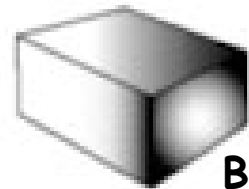
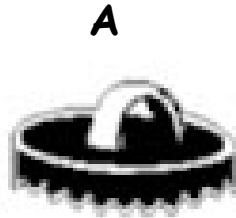

Parts of a Saddle (10 points)

Identify the parts of the saddle listed below.

*Girth

*Stirrup

*Pommel

*Seat

*Stirrup Leather

*Saddle Pad

*Handhold

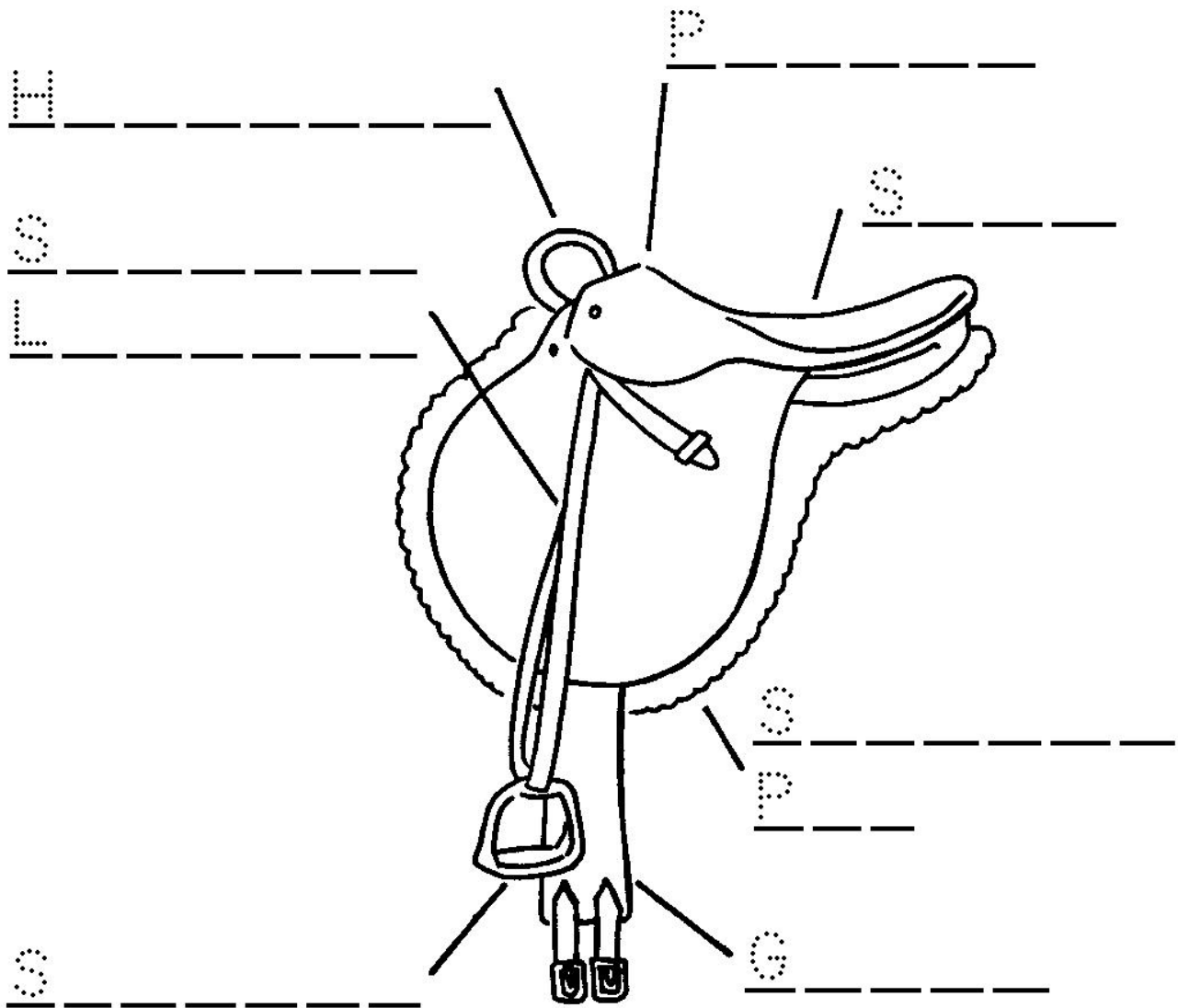

Parts of a Bridle (10 points)

Identify parts of the bridle listed below.

*Crown Piece

*Reins

*Cheek Pieces

*Throat Latch

*Nose Band

*Snaffle Bit

*Brow Band

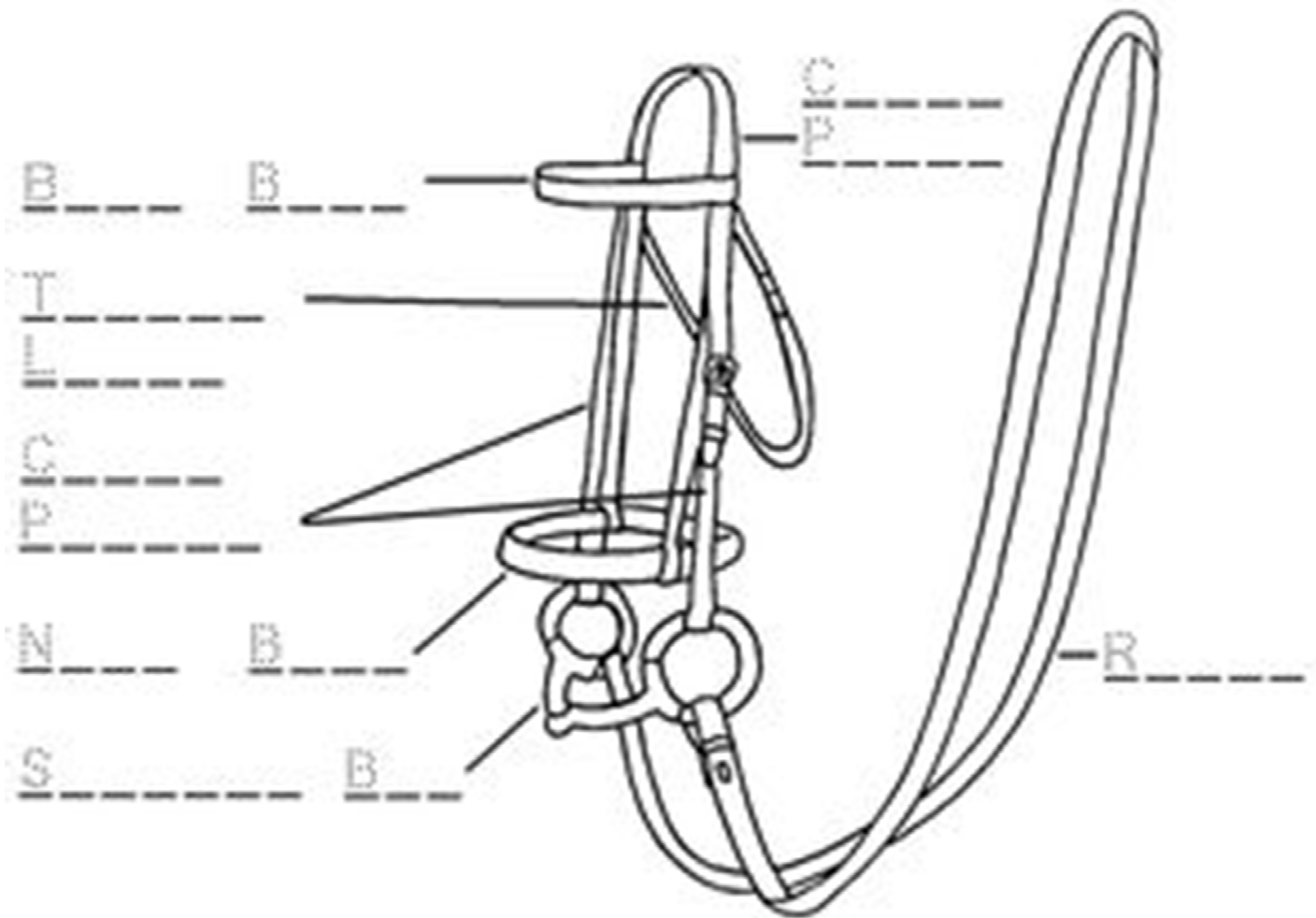

HORSE COAT COLORS & BREEDS

Colors: A good horseperson needs a working knowledge of horse colors. The first and most important group is the basic coat colors. There are five basic horse coat colors.



Bay: A bay colored horse may be hard to describe, but easy to distinguish. It is a mixture of red and yellow. A light bay shows more yellow and a dark bay, more red. The darkest is the mahogany bay, which is almost the color of blood, but without the overtones. Bays always have black points (black mane, tail and lower portion of the legs, except for any white marking on the legs).

Black: A black horse almost invariably has black eyes, hooves and skin, the points are also black. Tan or brown hairs on the muzzle or flank indicated that the horse is not a true black but a seal brown.

Brown: A brown horse is one with brown coloration. Many brown horses are mistakenly called black, because they are so dark. A close examination of the hair on the muzzle and around the lips will quickly tell whether the horse is brown or black. The mane and tail are always dark.

Chestnut: (Sorrel) A chestnut horse is basically red. The mane and tail are normally the same shade as the body. If the mane and tail are lighter in color than the body, the horse is termed a flax or flaxen chestnut. The mane and tail of a chestnut horse are never black. Chestnut varies from a bright yellowish red to a rich mahogany red.

White: A white horse has snow-white hair, pink skin and brown eyes. The true white is born pure white and dies the same color. Very little, if any, seasonal change takes place in the coat color. Age does not affect it.

Breeds: There are more than 350 breeds of horses and ponies. From working and racing to casual riding and equestrian competition, each horse has its special qualities. But there are five particular breeds that stand out and capture the hearts of horse lovers everywhere.

1. American Quarter Horse:
2. Arabian
3. Thoroughbred
4. Appaloosa
5. Morgan

****Now that you are familiar with the basic horse colors and horse breeds, please complete the following pages.****



Identification of Two Horse Colors (10 points)

(Pictures and Descriptions)

1. _____

Description of Horse Color: _____

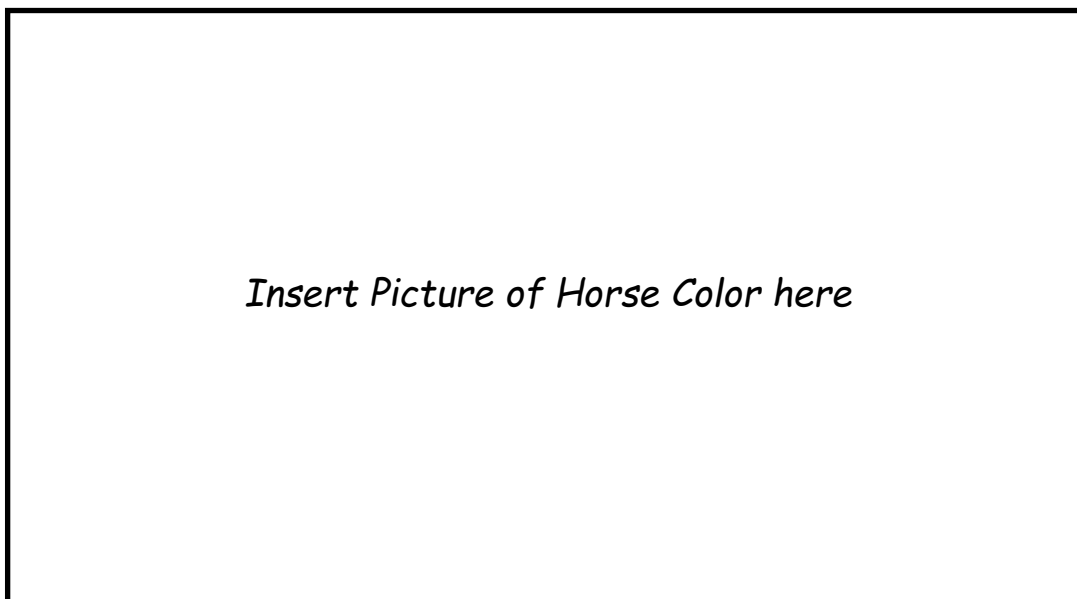

2. _____

Description of Horse Color: _____

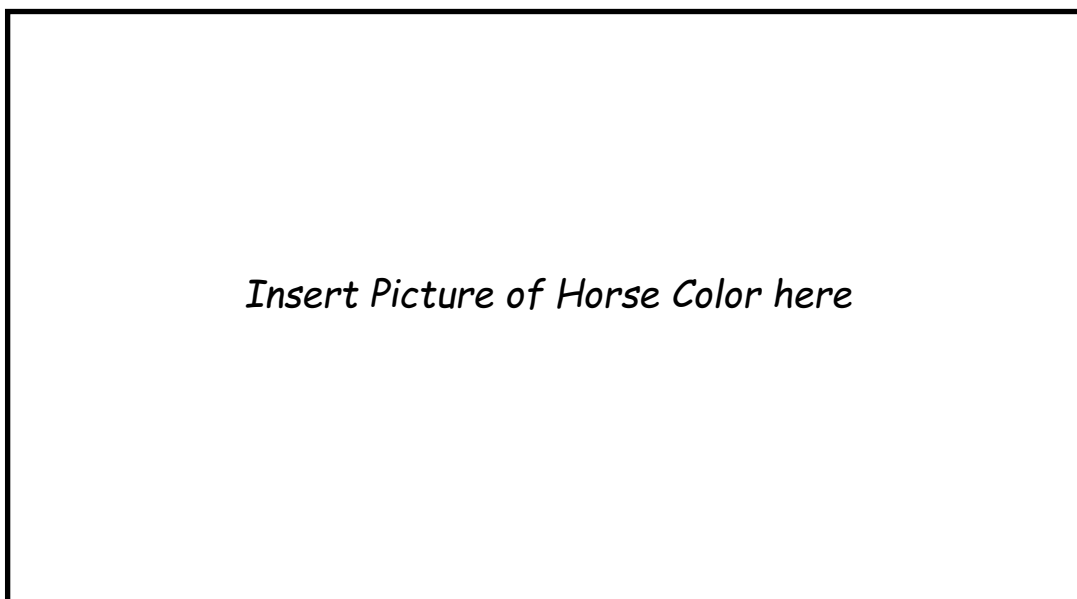

Identification of One Horse Breed (10 points)

(Picture and Characteristic)

1. _____

Characteristics of Horse Breed: _____

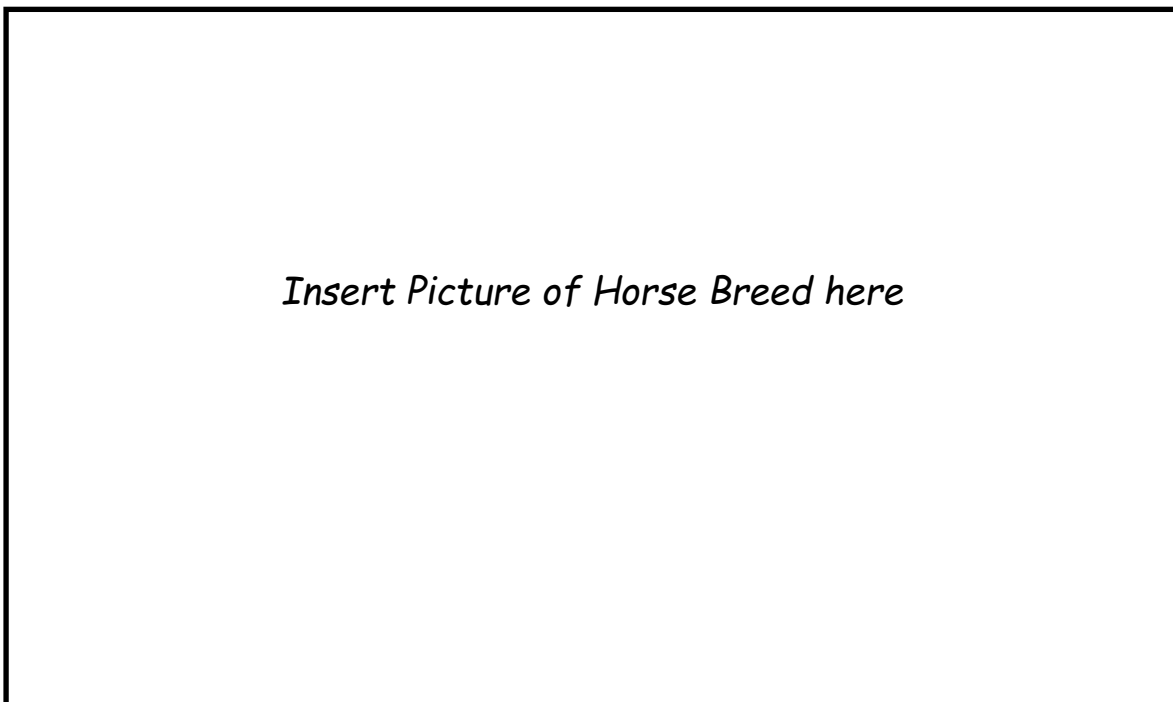



4-H Horsemaster Level 1 Level 1 Completion Signatures



Once you have completed this book, you will need to sign this page. Your leader and a parent/guardian will also look through this booklet and sign in the spaces below.

4-H Member Signature	Date Signed

Parent/Leader Signatures:

By signing below, I am stating that I have reviewed this 4-H member's Horsemaster Level 1 book, and to the best of my knowledge, the member completed this book on their own and the information provided is correct.

Title	Signature	Date Signed
Parent/ Guardian		
4-H Leader		

MSU is an affirmative-action, equal-opportunity employer. Michigan State University Extension programs and materials are open to all without regard to race, color, national origin, gender, gender identity, religion, age, height, weight, disability, political beliefs, sexual orientation, marital status, family status or veteran status.

UNMOUNTED SKILLS LEVEL ONE

Correctly demonstrate the following skills to a designated leader or resource person
Leader, please mark an “X” in the “S” Column for **Successfully demonstrating** or
in the “G” column with **demonstrated with Guidance.**

		S	G	Date
1	Explain where the safety zones are when handling horses			
2	Explain which side to you lead the horse or mount the horse from			
3	Explain how horses see (their vision)			
4	Demonstrate how to safely approach a horse (with halter on) and lead it.			
5	Demonstrate how to correctly tie a horse with a safety knot			
6	Identify three basic grooming tools			
7	Demonstrate the use of the above three grooming tools, explain basic safety while grooming			
8	Correctly bridle their horse or pony (assistance ok)			
9	Correctly saddle their horse or pony. (assistance ok)			
10	Know how to perform a safety check before mounting.			
11	Demonstrate how to mount and dismount safely using correct form. (assistance ok)			
12	Demonstrate how to safely release your horse and remove the halter			
13	Demonstrate the proper S.E.I. helmet fit			
	Total			

RIDER'S NAME _____ DATE: _____

LEADER'S SIGNATURE _____ DATE: _____

General Comments

LEVEL ONE MOUNTED SKILLS EVALUATION

(Choice of Seat Optional)

Scoring System – 75% passing (with a minimum of 5 on each movement)

1-3 Unsafe - difficulty maintaining control

3-5 Attempt to perform movement but below requirements (Example: wrong lead uncorrected)

5-8 Movement performed with errors, but corrected (Example: leads, diagonals)

8-10 Movement performed correctly to exceptionally well

LEVEL ONE

	Possible	Score
Lead your horse or pony to evaluator, perform a tack check	10	
Mount your horse or pony (may be assisted)	10	
Walk on rail	10	
Circle at a walk	10	
Halt from a walk (pause 10 seconds)	10	
Trot / jog on rail	10	
Two point at a trot	10	
Circle at a trot	10	
Halt from a trot	10	
Back 4 steps	10	
Reverse on the haunches (pivot 180 degree turn)	10	

ADDITIONAL SCORING

Subtle use of aids	10	
Submission of horse to rider	10	
Correctness of position	10	
Balance and collection	10	
Overall safety awareness	10	

Total (160) _____

Rider's Name _____

General Comments of overall ride (may make suggestions for improvement)

Evaluator's Signature _____ Date _____